



OLYBOND500[®]

Insulation Adhesive

Description

OlyBond500[®] is a two-component, low-rise polyurethane adhesive used to adhere a variety of board stocks to many roof substrates in both new and reroof applications. It can also be used to adhere insulation board to insulation board. OlyBond500[®] is dispensed in 3/4" (19.1 mm) to 1" (25.4 mm) wide beads that spread to several inches while rising 3/4" (19.1 mm) to 1" (25.4 mm) above the substrate. Place the board stock into the adhesive and walk into place. A chemical cure takes place, securing the board in approximately 4 to 8 minutes after application, depending on temperature and weather conditions. OlyBond500[®] uses water, not HCFC, as the blowing agent and therefore is low VOC.

Basic Use

- OlyBond500[®] is included in many approved roof assemblies listed with UL, FM Approvals, and Miami-Dade County. Refer to UL Product iQ, Miami-Dade County, and FM Approvals at RoofNav.com for actual assemblies.
- Ensure that you have the correct OlyBond500[®] formulation for the surface and ambient temperature.
 - Regular** - All Packaging 40°F+ (4.4°C+)
 - Winter Grade** - Bag In Box/15 Gal (57 L) Drum 25°F - 65°F (13.8°C - 36.1°C)
 - Winter Grade** - SpotShot 0°F - 65°F (-17.8°C - 36.1°C)
- OlyBond500[®] is available in both Regular (Bag-in-Box, 15 Gal [57 L] Drums, 50 Gal [189.25 L] Drums, and SpotShot) and Winter Grade OlyBond500[®] Spot Shot Bag-in-Box for optimum application at various temperatures.
- Lightweight and portable.
- Allows for easy insulation board installation.
- Compatible with most single-ply and some asphaltic systems.
- Quick cure time.
- On retrofit re-cover projects, the existing roof material must be examined. All wet material must be identified and removed prior to the application of the OlyBond500[®] adhesive to ensure adequate attachment of existing system.
- See pages 3 – 4 for general application recommendations and requirements.

Packaging

- 10-gallon (37.85 L) Bag-in-Box sets for use with the PaceCart 2[®] and PaceCart 3[™] (5-gallon [18.93 L] Part 1; 5-gallon [18.93 L] Part 2).
- 30-gallon (57 L) Drum sets for use with PaceCart 3[™] with

conversion kit (15 gallon [57 L] Part 1; 15 gallon [57 L] Part 2.)

- 100-gallon (378.5 L) Drum Kit; (50 gallon [189.25 L] Part A; 50 gallon [189.25 L] Part B.)
- 1,500-ml SpotShot cartridge sets for use in specially designed applicators.

Compatibility When Properly Prepared and Evaluated

Roof Decks and Substrates:

- Structural concrete
- Gypsum
- Cementitious wood fiber plank
- Lightweight insulating concrete
- Steel (22 gauge or thicker with approved cross section)
- Plywood (5/8" [15.9 mm] thick min.)
- Smooth surface BUR
- Smooth and granular-surface modified bitumen (See the GAF published application and specifications manual available at gaf.com for proper preparations or contact GAF Technical Support at 1-800-766-3411.)
- Existing sprayed-in-place polyurethane foam
- Base sheets
- Asphaltic and fleece-top vapor barriers

Roof Insulation and Cover Board:

- Expanded polystyrene
- Polyisocyanurate and HD polyisocyanurate (4 ft. x 4 ft. [1.21 m x 1.21 m] boards)
- High-density wood fiber
- Gypsum cover boards
- Perlite
- Certain extruded polystyrene

Any substrate or insulation not listed must be reviewed by GAF. Call us at 800-766-3411.

Codes and Compliance

OlyBond500[®]

Physical Property	Test Method	Typical Values
Density	ASTM D1622	5.03 lb/cf
Compressive Strength	ASTM D1621	18.02 psi @ 10% deformation
Tensile Strength	ASTM D1623	2.04 psi
Water Absorption	ASTM D2842	2.75%
Closed Cell Content	ASTM D6226	90% min
VOC Content	EPA Method 24	Regular: 11 g/L Winter: 50 g/L
Weight/Gallon		10.32 lb.; 8.54 lb.

Description	Packaging Type	Weight
OlyBond500 [®] Part 1 (Regular & Winter Grade)	Bag-in-Box 5 Gallon (18.9 L)	53 lb. (24.06 kg)
OlyBond500 [®] Part 2 (Regular & Winter Grade)	Bag-in-Box 5 Gallon (18.9 L)	45 lb. (20.43 kg)
OlyBond500 [®] SpotShot Cartridge (Part 1 & Part 2) (Regular & Winter Grade)	(4) 1500 ml Cartridges /Box	19 lb. (8.62 kg)
OlyBond500 [®] Part 1	15 Gallon (56.78 L) Drum	160 lb. (72.64 kg)
OlyBond500 [®] Part 2	15 Gallon (56.78 L) Drum	135 lb. (61.29 kg)
OlyBond [®] Part A	50 Gallon (208.2 L) Drum	553 lb. (251 kg)
OlyBond [®] Part B	50 Gallon (208.2 L) Drum	465 lb. (211 kg)



Manufactured by:



Florida Building Code Approved



Distributed by:

GAF

OLYBOND500[®]

Insulation Adhesive

PaceCart 2[®] and PaceCart3[™] for OlyBond500[®]

Patented PaceCart 2[®] and PaceCart3[™] are the exclusive pieces of application equipment for OlyBond500[®] using patented Bag-in-Box technology.



- Helps with fast adhesive application
- Designed for large roof projects
- Low installed cost method of application
- Can apply up to 60 squares of insulation per hour using the PaceCart 2[®] and up to 120 squares of insulation per hour using the PaceCart3[™]
- Two-component reaction occurs in the disposable mix tips, keeping the gun and hoses clean and free flowing
- 30-ft. (9.14 m) hose allows for easy application around penetrations
- Use OMG PCPreserver[™] to keep pumps, hoses, and gun assembly sufficiently lubricated during storage
- Easy to clean and maintain
- Clean, airtight delivery system
- Built-in tool box holds extra mix tips, grease gun, etc.

SpotShot Applicators

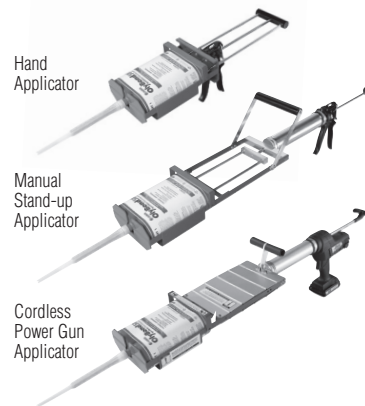

Cordless Power Gun Applicator

- All the benefits of the manual stand-up applicator plus a battery-powered mechanical drive system
- Constant pressure provides even and uninterrupted adhesive flow for maximum efficiency
- Easy to operate
- Includes two (2) batteries and a 120-volt charger

Hand Applicator

- Lightweight and easy to use
- Great for repair work or small areas
- Inexpensive

Manual Stand-Up Applicator

- Lightweight and portable
- Stand-up application helps reduce worker fatigue as compared with hand applicators

Product Installation

Job Conditions:

- Ensure that you have the correct OlyBond500[®] formulation for the surface and ambient temperature.
 - **Regular** - All Packaging 40°F+ (4.4°C+)
 - **Winter Grade** - Bag In Box/15 Gal (57 L) Drum 25°F - 65°F (13.8°C - 36.1°C)
 - **Winter Grade** - SpotShot 0°F - 65°F (-17.8°C - 36.1°C)

Roof Deck Criteria

1. OlyBond500[®] can only be installed on acceptable substrates (i.e., structural concrete, gypsum, cementitious wood fiber plank, lightweight insulating concrete, minimum 22-gauge steel, and minimum 5/8" [15.9 mm] plywood) that have been properly prepared. The structure must be sufficient to withstand normal construction load and live loads.
2. Defects in the deck must be repaired prior to re-roof. The application of OlyBond500[®] should not proceed unless the defects are corrected.
3. It is the responsibility of the roofing contractor to ensure that the existing roof is adequately attached to the building.

Surface Preparation

- **General:** All surfaces must be clean, dry, and free of any debris, dirt, oil, or grease before applying OlyBond500[®].
- **Specific Conditions**
 - **Steel** - The bonding surface of steel decks must be dry and free of debris, dirt, grease, and oil. On new steel, the shop coating/mill oil must be removed. The bonding surface must be free of any cleaner before applying OlyBond500[®].
 - **Existing Smooth Asphaltic Surfaces** - The surface must be dry and free of debris, dirt, grease, and oil.
 - **Existing Polyurethane Foam** - The surface of the polyurethane roof, including the coating, should be removed with a scarifier (minimum 1/2" [12.7 mm]). The bonding surface should be blown clean before applying OlyBond500[®].
 - **Metal** - It is recommended that all non-ferrous metals (aluminum, copper, stainless, etc.) be primed to increase adhesion. Acceptable primers include GAF Epoxy Primer, chlorinated rubber, and wash primer. Contact GAF for further requirements and restrictions.
 - **Concrete** - All concrete surfaces must be fully cured prior to applying OlyBond500[®].
- For detailed GAF substrate preparation requirements, please refer to the appropriate GAF Application and Specifications Manual or contact GAF at 1-800-766-3411.

Manufactured by:





OLYBOND500[®]

Insulation Adhesive

Product Installation

• Using PaceCart 2[®] and PaceCart3[™]

- Install Part 1 and Part 2 components following instructions on Bag-in-Box package or 15 gallon conversion kit.
- Open flow valves on the dispenser completely and turn machine on. This allows adhesive to be pumped at a 1:1 ratio through the disposable mix tip and onto the substrate in a semi-liquid state.
- Apply fluid mixture ¾" – 1" (19.1 mm – 25.4 mm) wide wet beads spaced a maximum of 12" (305 mm) on center that spreads in excess of 2" (51 mm) wide while rising to ¾" – 1" (19.1 mm – 25.4 mm).
- Lay insulation board into place and walk-in to ensure complete adhesion. Curing typically occurs in 4 to 8 minutes depending on temperature and weather conditions.
- For detailed GAF substrate preparation requirements, please refer to the appropriate GAF Application and Specifications Manual or contact GAF at 1-800-766-3411.

• Using SpotShot Applicator

- Attach the disposable mix tip to the top of the SpotShot tube. Insert the tube into the SpotShot dispensing tool and dispense onto the substrate. Apply fluid mixture in ¾" – 1" (19.1 mm – 25.4 mm) wide wet beads in rows spaced a maximum of 12" (305 mm) on center that spread in excess of 2" (51 mm) wide while rising to ¾" – 1" (19.1 mm – 25.4 mm).
- Lay insulation board into place and walk-in to ensure complete adhesion. Curing typically occurs in 4 to 8 minutes depending on temperature and weather conditions.
- For detailed GAF installation requirements, please refer to the appropriate GAF Application and Specifications Manuals or contact GAF at 1-800-766-3411.

Typical Coverage Rates

Coverage rates vary depending on surface roughness and absorption rate of the substrate. Typical coverage rates for OlyBond500[®] dispensed through the PaceCart[®] are up to 25 squares per 10-gallon (37.85 L) Bag-in-Box sets and 75 square per 15-gallon (68.19 L) or 50 gallon (189.25 L) drum sets. Typical coverage rate for OlyBond500[®] SpotShot dispensed through applicators is 4 – 6 squares per case (4 sets of 1,500-ml cartridges). See chart below for typical coverage rates on specific substrates.

Application Rates (Bag-in-Box Dispensed from PaceCart [®])	Typical Coverage* Squares/Gallon
Insulation to Concrete	up to 2.5
Insulation to Insulation	up to 2.5
Insulation to Smooth BUR	up to 1.7
Insulation to Modified Bitumen	up to 1.7
Insulation to Gypsum	up to 1.2
Insulation to Lightweight Concrete	up to 1.7
Insulation to Wood	up to 2.5
Insulation to Cementitious Wood Fiber	up to 1.2
Insulation to Steel	up to 1.4

*All coverage rates are based on 12" (305 mm) on center maximum spacing

Reaction Time

It is important to monitor the speed of the reaction in relation to the temperature (substrate and ambient) at the time of application to ensure a complete reaction. Note the charts below for correct "Part 2" component selection:

Typical Reaction Time Characteristics

A. 5-, 15-, and 50-Gallon Bag-in-Box Packaging

Temperature	Part 2 Formula	Tack-Free Time (minutes)	Set-Up Time* (minutes)
25°F to 65°F	W	3-4	10-12
40°F+	R	3-5	10-12

B. 1500 ml SpotShot Cartridges

Temperature	Part 2 Formula	Tack-Free Time (minutes)	Set-Up Time (minutes)
0°F – 65°F	W	3-4	10-12
40°F+	R	3-5	10-12

Important: When applying OlyBond500[®], board stock must be placed into the adhesive shortly after it has reached its maximum rise while it is still wet and tacky and before it reaches its tack-free state. Do not install boards if adhesive is skinned over.

*Time from adhesive application to insulation board installation





OLYBOND500[®]

Insulation Adhesive

Precautions

- **In Case of Fire:** Use water spray, foam, or CO₂. Firefighters should be equipped with self-contained breathing apparatus and turnout gear for protection against PMDI vapors and toxic decomposition products. Avoid water contamination in closed container or confined areas.
- **Do Not Leave Adhesive Exposed or Unprotected.** Polyurethane foam or isocyanurate foam products may present a serious fire hazard if exposed or unprotected. Each person, firm, or corporation engaged in the manufacture, production, application, installation, or use of any of these materials should carefully determine whether there is a potential fire hazard associated with such product in a specific usage and utilize all appropriate precautionary and safety measures as outlined in local, state, and federal regulations. When not in use, keep stored containers closed.

First Aid

In case of contact with eyes, immediately flush eyes with running water for at least 15 minutes. Call a physician immediately. In case of contact with skin, wash affected area with soap and water. Remove all contaminated clothing and shoes and clean before re-use. If swallowed, give large amounts of water to dilute. If vomiting occurs, give more water. Call a physician immediately.

Disposal

Do not discharge into lakes, streams, ponds, or public waters. Spilled material, unused contents, and empty containers should be disposed of in accordance with local, state, and federal regulations.

Patent Notice

The OMG PaceCart[®] dispensing cart and the Bag-in-Box OlyBond500[®] Part 1/Part 2 adhesive system, including the adhesive dispensing method, are covered by one or more of U.S. Patent Nos. 6,220,526; 8,113,385; 8,132,693; 8,167,170; 8,342,372; 8,474,658 and 9,327,308; and Canadian Patent No. 2,591,502, Canadian Parent No. 2,821,451 and U.S. Patent Pending.

Limitations

- OlyBond500[®] is not recommended for use with Polyisocyanurate board stock larger than 4' x 4' (1.21 m x 1.21 m).
- OlyBond500[®] is not recommended for use during wet weather.
- OlyBond500[®] cannot be used on dirty or grease-laden surfaces.
- OlyBond500[®] is not recommended for use on any roof deck that shows signs of deterioration or loss of structural integrity.
- OlyBond500[®] is not recommended for use after the expiration date. Contact OMG at 800-633-3800 for options and instructions.

Storage and Handling

- Store in a cool, dry location at temperatures between 55°F (12.8°C) and 85°F (29.4°C). Protect from freezing at all times. If properly stored, the shelf life for unopened product is 18 months from the date of manufacture.
- Keep containers closed. Contamination by moisture or basic compounds can cause dangerous pressure build-up in a closed container.
- The minimum product temperature before application should be 72°F (22.2°C). The minimum ambient and surface temperatures should be 40°F (4.4°C) and rising unless the SpotShot winter formulation is being used.

Manufactured by:

