

Installation Guide for EverGuard Standard Gravel Stop Fascia

1 CAMPUS DRIVE, PARSIPPANY, NJ 07054 USA
973-628-3000
WWW.GAF.COM



Installation Guide for EverGuard Standard Gravel Stop Fascia

APPROVALS: Contact manufacturer for verification of test report data on your project.

ANSI/SPRI/FM4435
/ES-1 TESTED

FM
Approved

NOTES:

- #1 - Isolate all metal parts from ACQ treated wood or other galvanically incompatible material with appropriate membrane material.
- #2 - Appliance attachments, such as lightning rods, signs, or antennae that penetrate the water seal, induce a galvanic reaction, or otherwise compromise the effectiveness of the roof edge system, shall be eliminated or isolated to prevent problems per section 8.0 of ANSI/FM4435/SPRI ES-1. Appliances shall be isolated from or not attached to the roof edge system. Consult the lightning protection system manufacturer for specific attachment instructions.

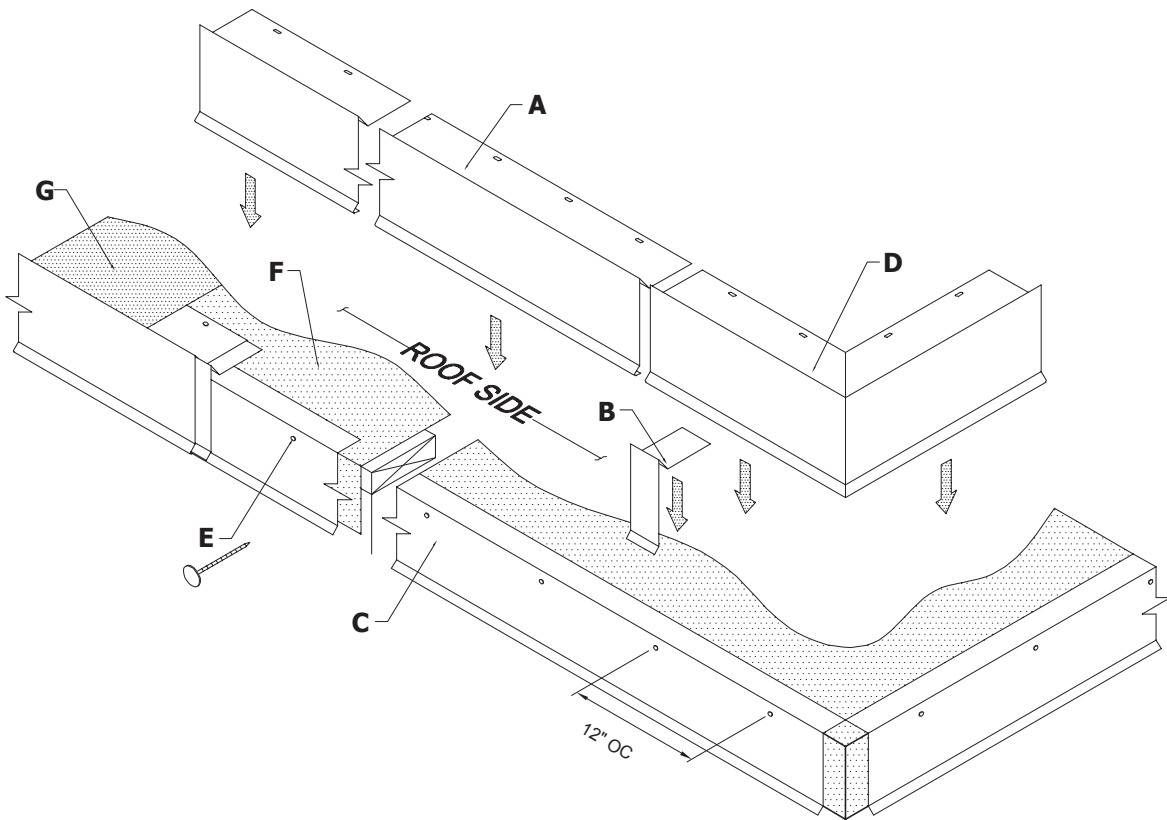
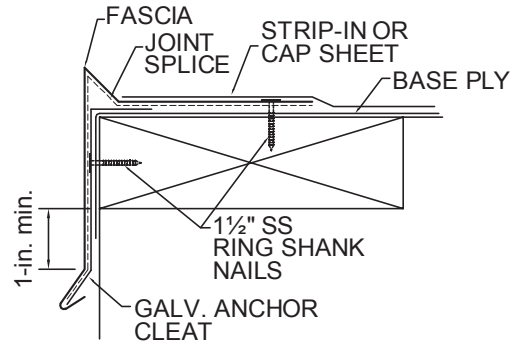

- A. Formed Fascia Cover**
10-ft. Lengths
- B. Concealed Joint Splice**
4-in. Lengths
- C. Galvanized Anchor Cleat**
10-ft. Lengths
- D. Fascia Miter Cover**
(Outside Corner Shown)

- E. 1 1/2-in. SS Ring Shank Nail**
at 12-in. o.c. (6-in. from ends) for cleat
at 12-in. o.c. (6-in. from ends) for cover
(Included & Required)
- F. Base Ply**
(By Installer)
- G. Strip-In Ply**
(By Installer)

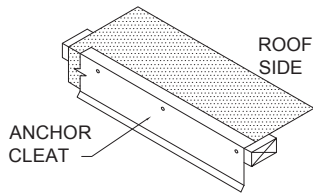

STEP 1: Installing Anchor Cleat

Place the top lip of the continuous anchor cleat squarely on the top edge of the roofing membrane and treated wood nailer. Press cleats securely in position and nail through the pre-punched holes with 1½-in. ss ring shank nails provided. For miter application, fit into corner as required to maintain a continuous anchor cleat line. Then nail at a min. 6-in. in each direction from the corner or closer at special conditions.

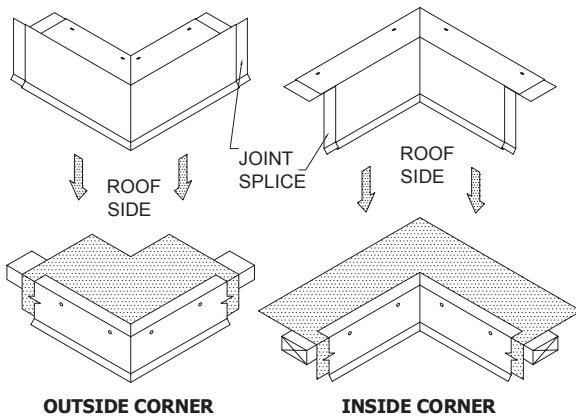

STEP 2: Installing Fascia Miters

Locate the miters and concealed joint splices for the appropriate corners. Place a concealed joint splice under each end of the miter sections. Install the miter by hooking the drip of the fascia miter onto the kick out of the cleat and rotate back onto the roof. Fasten with 1½-in. ss ring shank nails provided in each pre-punched hole.

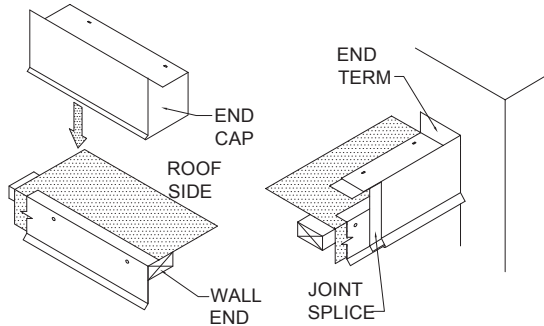

STEP 3: Installing Fascia End Caps and End Terms

Install the fascia end caps and end terms by hooking the drip of the fascia onto the kick out of the cleat and rotate back onto the roof. Fasten with 1½-in. ss ring shank nails provided in each pre-punched hole.

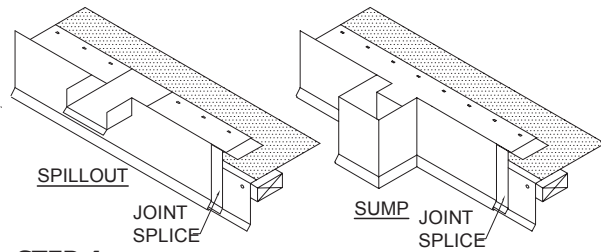

STEP 4: Installing Sumps and Spillouts

Place a concealed joint splice in both ends of the sump/spillout. Install by hooking the drip of the fascia onto the kick out of the cleat and rotate back onto the roof. Fasten with 1½-in. ss ring shank nails provided in each pre-punched hole.

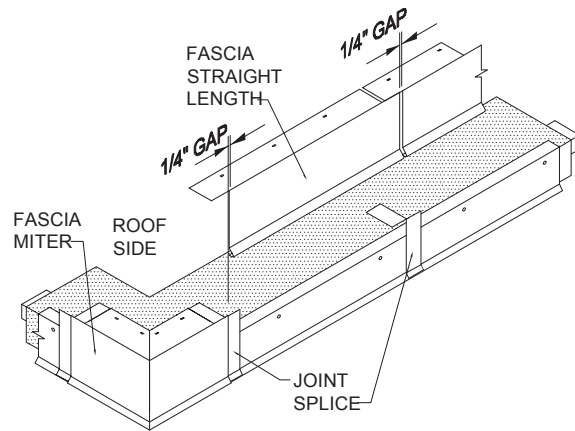

STEP 5: Installing Fascia Straight Lengths

Place a concealed joint splice in the opposite end of the installed miter or end cap. Install the fascia by hooking the drip of the fascia onto the kick out of the cleat and rotate back onto the roof. Fasten with 1½-in. ss ring shank nails provided in each pre-punched hole. **Allow ¼-in. gap between fascia sections for thermal expansion.** Consider lengths of all straight pieces prior to cutting to avoid creating relatively short sections of fascia adjacent to full length sections. **Note: There should be a joint splice at every joint.**

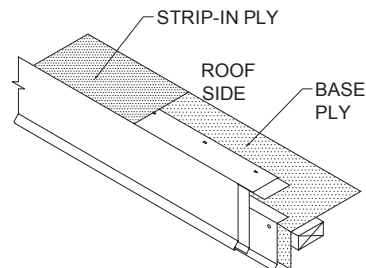

STEP 6: Installing Approved Roofing Membrane

Install roofing membrane per manufacturer's instructions.