

ALTERNATE INSTALLATION

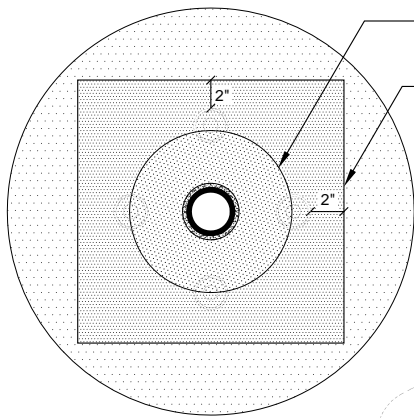

SEE NOTE #1

EVERGUARD® SPLIT PIPE BOOT

TARGET MADE FROM
EVERGUARD® TPO MEMBRANE

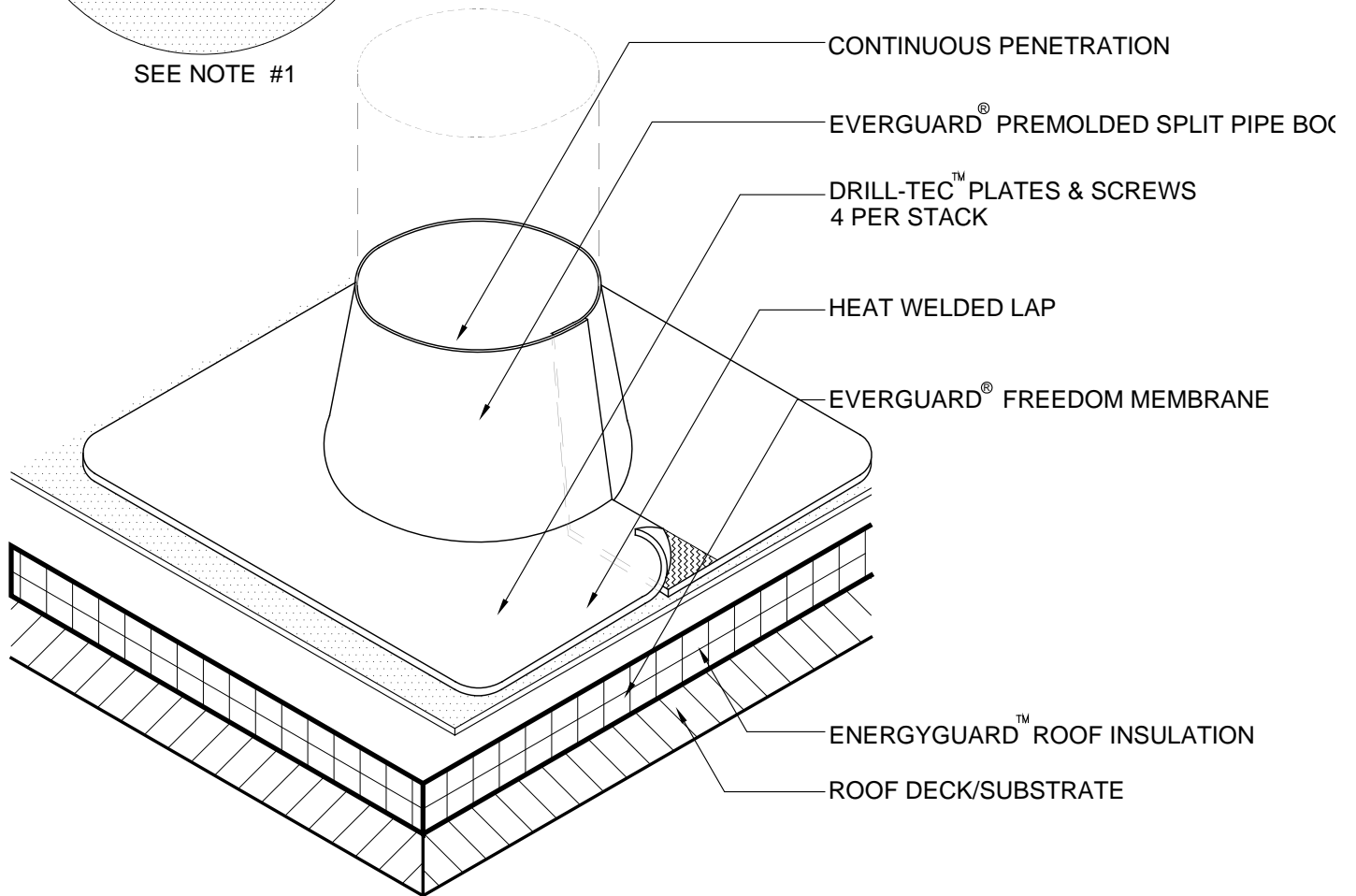

CONTINUOUS PENETRATION

EVERGUARD® PREMOLDED SPLIT PIPE BOOT

DRILL-TEC™ PLATES & SCREWS
4 PER STACK

HEAT WELDED LAP

EVERGUARD® FREEDOM MEMBRANE

ENERGYGUARD™ ROOF INSULATION

ROOF DECK/SUBSTRATE

NOTE:

1. TO MAKE A SEAM ON RAPID SEAM™ WITHOUT RAPID SEAM™ PRESENT, YOU MUST USE GAF CLEANER AS WELL AS GAF PRIMER TO PREP THE AREA.
2. IF THE PLATES AND FASTENERS INTRUDE INTO BOOT FLANGE AREA, THEN A TARGET MUST FIRST BE INSTALLED OVER PLATES AND FASTENERS BEFORE BOOT INSTALLATION.
3. APPLY EVERGUARD® TPO CUT EDGE SEALANT TO ALL CUT REINFORCED TPO EDGES (REFER TO DETAIL FD 115) AND ALL RAPIDSEAM™ SEAMS.



ROOF PENETRATION
SERIES

SPLIT PIPE BOOT

HEATWELD & RAPIDSEAM

DRAWING #

524

SCALE

N.T.S.

SYSTEM

FD

ISSUE/ REVISION DATE

3-1-10