

ALTERNATE INSTALLATION

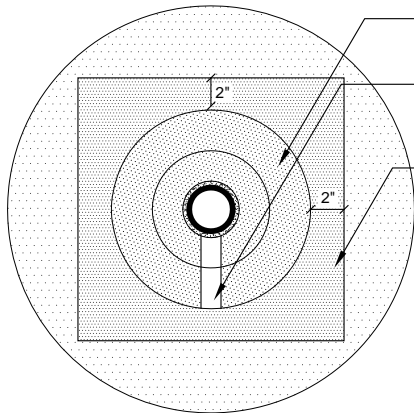

SEE NOTE #2

EVERGUARD® PREMOLDED VENT BOOT

4" WIDE MIN. EVERGUARD® FLASHING STRIP

TARGET MADE FROM EVERGUARD® TPO MEMBRANE

STAINLESS STEEL CLAMP

VENT STACK

EVERGUARD® GUN GRADE SEALANT

GAF WATER BLOCK

EVERGUARD® BONDING ADHESIVE (OPTIONAL)

EVERGUARD® FLASHING MEMBRANE

DRILL-TEC™ PLATES & SCREWS 4 PER STACK

EVERGUARD® MEMBRANE TARGET

HEAT WELDED LAP

EVERGUARD® FREEDOM MEMBRANE

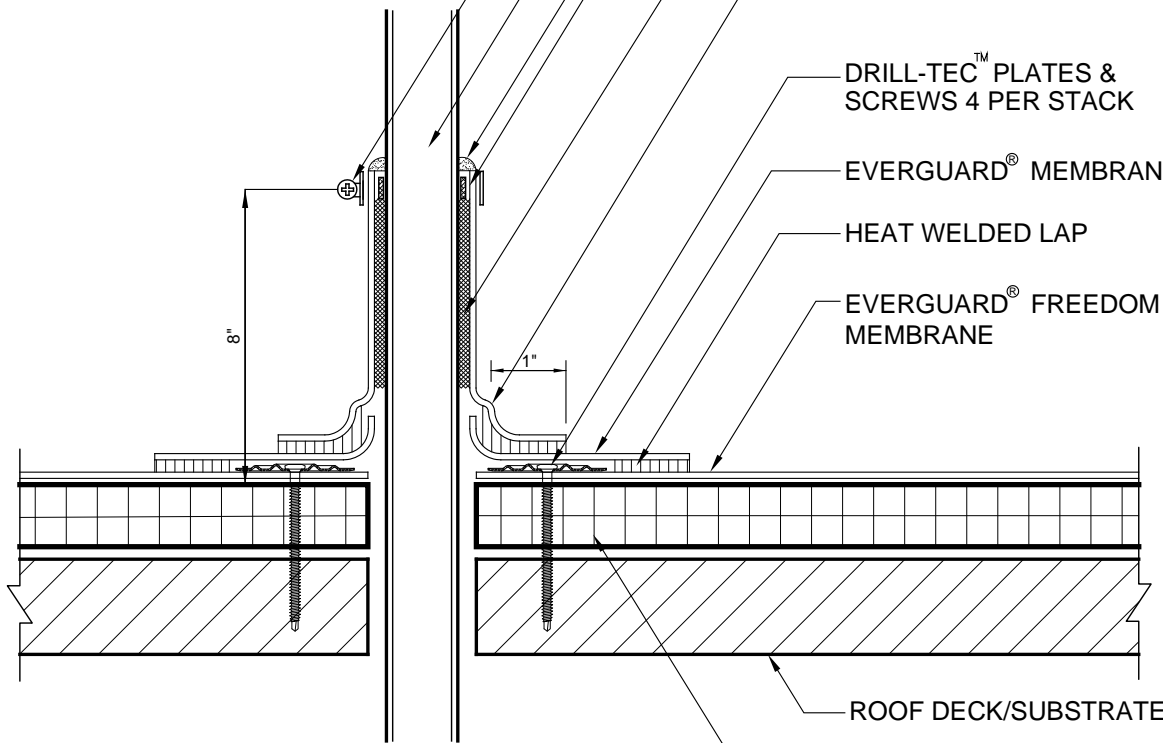

ROOF DECK/SUBSTRATE

ENERGYGUARD™ ROOF INSULATION

NOTE:

1. IF TARGET MEMBRANE MUST BE SPLIT TO FIT AROUND STACK, A MIN. 4" WIDE EVERGUARD® FLASHING STRIP MUST BE HEAT WELDED OVER SPLIT.
2. IF THE PLATES AND FASTENERS INTRUDE INTO BOOT FLANGE AREA, THEN A TARGET MUST FIRST BE INSTALLED OVER PLATES AND FASTENERS BEFORE BOOT INSTALLATION.
3. APPLY HEAT TO UNREINFORCED FLASHING AND FORM BY HAND PRIOR TO HOT AIR WELDING.
4. APPLY EVERGUARD® TPO CUT EDGE SEALANT TO ALL CUT REINFORCED TPO EDGES (REFER TO DETAIL FD 115) AND ALL RAPIDSEAM™ SEAMS.

**RAPID SEAM™
MAX 10 YR
GUARANTEE**



ROOF PENETRATION SERIES

FIELD-WRAPPED PENETRATION FLASHING

HEATWELD & RAPIDSEAM

DRAWING #

507

SCALE

N.T.S.

SYSTEM

FD

ISSUE/ REVISION DATE

3-01-10