

ALTERNATE INSTALLATION

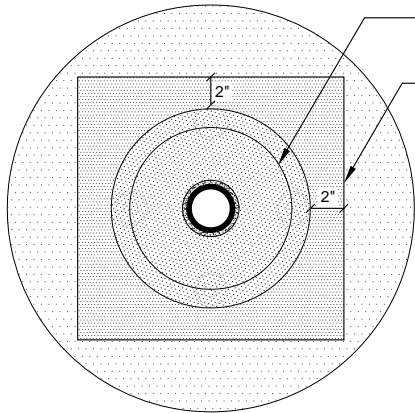

SEE NOTE #3

EVERGUARD® PREMOLDED VENT BOOT

TARGET MADE FROM  
EVERGUARD® TPO MEMBRANE

STAINLESS STEEL CLAMP

VENT STACK

EVERGUARD® GUN GRADE SEALANT

GAF WATER BLOCK

EVERGUARD® PREMOLDED VENT BOOT

DRILL-TEC™ PLATES & SCREWS 4  
PER STACK

HEAT WELDED LAP

EVERGUARD® FREEDOM MEMBRANE

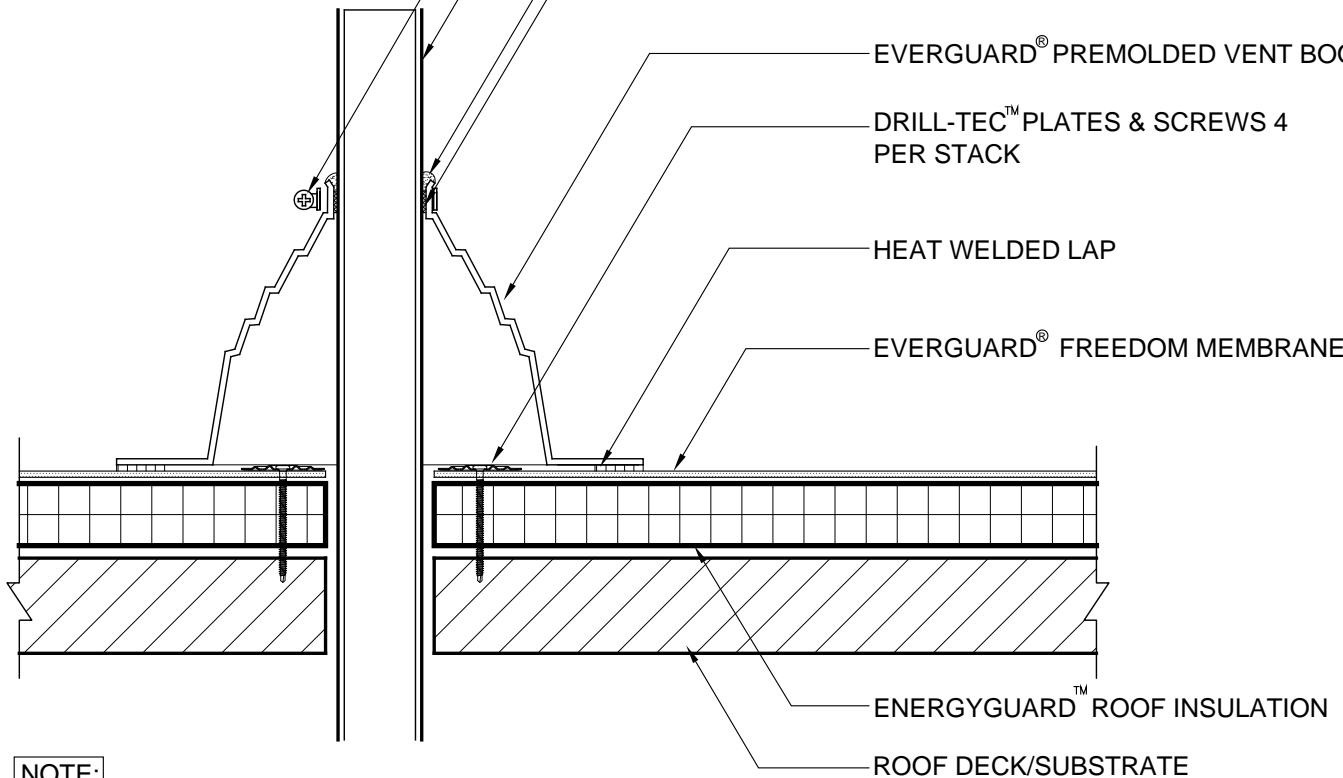

ENERGYGUARD™ ROOF INSULATION

ROOF DECK/SUBSTRATE

NOTE:

1. TO MAKE A SEAM ON RAPID SEAM™ WITHOUT RAPID SEAM™ PRESENT, YOU MUST USE GAF CLEANER™ AS WELL AS GAF PRIMER TO PREP THE AREA.
2. DO NOT CUT PREMOLDED BOOT VERTICALLY, IT MUST BE PULLED OVER VENT PIPE.
3. TPO SELF-ADHERED PIPE BOOTS AND PRIMER MAY BE USED WITH TPO SYSTEMS FOR UP TO A 15 YEAR GUARANTEE.
4. IF THE PLATES AND FASTENERS INTRUDE INTO BOOT FLANGE AREA, THEN A TARGET MUST FIRST BE INSTALLED OVER PLATES AND FASTENERS BEFORE BOOT INSTALLATION.
5. APPLY EVERGUARD® TPO CUT EDGE SEALANT TO ALL CUT REINFORCED TPO EDGES (REFER TO DETAIL FD 115) AND ALL RAPIDSEAM SEAMS.



EverGuard  
**Freedom**  
Self-Adhering Roofing System

ROOF PENETRATION  
SERIES

PREMOLDED VENT BOOT FLASHING

HEATWELD & RAPIDSEAM

DRAWING #

506A

SCALE

N.T.S.

SYSTEM

FD

ISSUE/ REVISION DATE

3-1-10