

Drill-Tec™ Locking Impact Nail

Data Sheet

Updated: 8/09



**Quality You Can Trust Since 1886...
From North America's Largest Roofing Manufacturer!™**

GYPSUM/TECTUM/LIGHTWEIGHT INSULATION CONCRETE

DRILL•TEC™

For Attaching Base Ply, Recovery Board and Insulation to Cementitious Wood Fiber, Poured Gypsum Decks, and LWIC (Light Weight Insulating Concrete).

COMPOSITION

Factory preassembled components consisting of:

Tube: Precision formed from Galvanized (G-90) coated steel to prevent corrosion. The tube is shaped to easily penetrate decking and existing membranes.

Disk: Precision formed from Galvalume (AZ-55) coated steel to prevent corrosion. Securely clamped to the tube, 2.7" diameter, rib reinforced to resist cupping.

Locking Staple: Precision formed from high tensile steel wire. Coated to prevent corrosion.

TECHNICAL DATA

Approvals: Factory Mutual and Metro-Dade County Approved.

Fastening Pattern: Consult Factory Mutual or Metro-Dade County requirements for recommended patterns in normal, exposed, and hurricane areas.

Field Testing: On-site withdrawal testing should always be performed to evaluate the ability of the roofing substrate to satisfactorily accept and retain fasteners. Such testing may alter fastener selection and modify applicable fastening patterns.

The Locking Impact Nail should always be embedded into the structural roof deck to a depth of at least 1".

INSTALLATION

Installation Tools: There are two tools that must be used to install the Locking Impact Nail. The Locking Impact Nail Driver-BS is for installing base sheet and recovery board to the substrate. For securing ISO or EPS to the substrate use the Locking Impact Nail-IN, which has a larger impact area. Consult BMCA for the specific driver for your application.

Method: Drive fastener perpendicular to roof deck seating disk/plate flush with roofing surface. Once tube is set, drive the locking staple thru the tube/disk unit into the deck until the top of the staple is flush with the cap (see illustration).

Operation: When locking staple is driven, its dual wire legs diverge anchoring the fastener in place (see illustration). Uplift resistance may vary depending on the density and integrity of the substrate.

Packaging: 1.4", 1.8", 2.8", and 3.8" Locking Impact Nails packaged 500 per carton. 4.8" Locking Impact Nails packaged 250 per carton.

MADE IN THE U.S.A.



Quality You Can Trust Since 1886...
from North America's Largest
Roofing Manufacturer™

LOCKING IMPACT NAIL

FIRST IMPACT SETS TUBE.

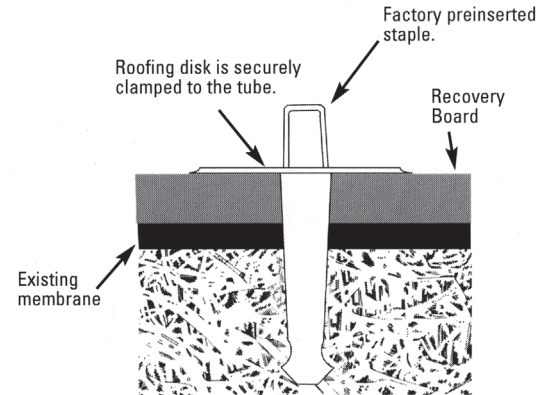

SECOND IMPACT ACTUATES STAPLE.

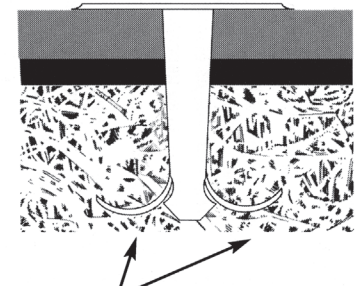

As locking staple is driven, its dual wire legs diverge anchoring the fastener in place.

5 LENGTHS

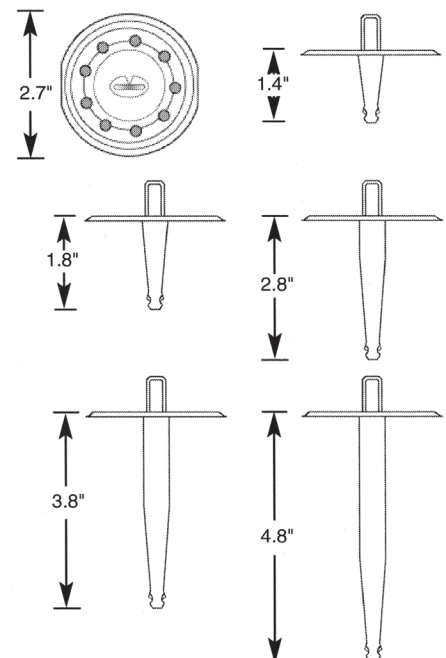

GYP SUM/TECTUM/LIGHTWEIGHT INSULATION CONCRETE

USING THE DRILL-TEC™ LOCKING IMPACT NAIL

Fastener density and spacing vary depending on applicable uplift requirements. Local codes, governing approval bodies, membrane manufacturers, and individual roof deck manufacturers all may have specific requirements that need to be addressed prior to beginning any roofing project. **The Locking Impact Nail should always be embedded into the structural roof deck to a depth of at least 1".** The following illustrates typical Factory Mutual recommended fastening patterns widely accepted by membrane and roof deck manufacturers.

Fastening Guide 1

Base Ply Attachment for built-up or modified bitumen roof covers.

Class I-60, I-75, or I-90 Windstorm Classification.

An FMRC Approved base ply is fastened in the field of the roof with Locking Impact Nail installed 9" on center in the 2" wide base ply side laps and 18" on center staggered in 2 rows, equally spaced, between the base ply side laps.

When fastening meter-wide material with this pattern, expect to use approximately 86 fasteners per square (100 ft.²).

Fastening Guide 2

Recovery board and Insulation attachment under built-up and modified bitumen roof covers.

Class I-90 Windstorm Classification.

An FMRC Approved Recovery Board/Insulation suitable for use with minimum 3 ply built-up or modified membranes is attached with 8 Locking Impact Nail fasteners per 4' x 4' board in a diamond-in-a-box pattern. (1 fastener per 2 ft.²)

Consult FMRC for a complete listing of approved recovery boards/insulations.

Fastening Guide 3

Recovery board and insulation attachment under fully adhered single ply membranes.

Class I-90 Windstorm Classification.

An FMRC Approved Recovery Board/Insulation suitable for use with fully adhered single ply membranes is attached with 12 Locking Impact Nail fasteners per 4' x 4' board in 4 rows of 3 fasteners per row. (1 fastener per 1.33 ft.²)

Consult FMRC for a complete listing of approved recovery boards/insulations.

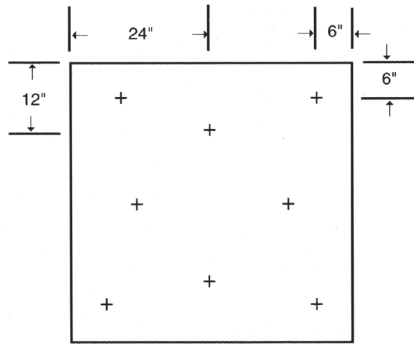
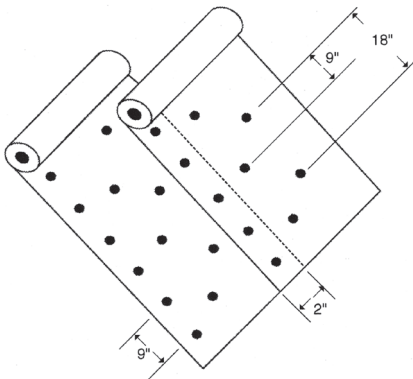

8 Fasteners

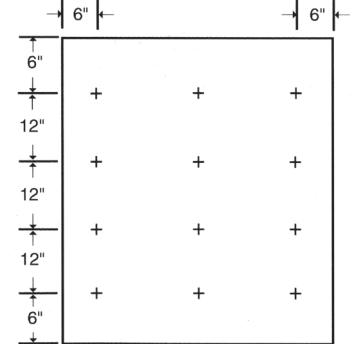

12 Fasteners

PHYSICAL DATA	SKU #	Length	Packaging	Weight	Qty/Skid
1.4" Locking Impact Nail	45D1	1.4"	500	26 lb	13,500
1.8" Locking Impact Nail	45D2	1.8"	500	28 lb	13,500
2.8" Locking Impact Nail	45D3	2.8"	500	34 lb	13,500
3.8" Locking Impact Nail	45D4	3.8"	500	42 lb	13,500
4.8" Locking Impact Nail	45D5	4.8"	250	27 lb	6,750
Locking Impact Nail Driver-BS*	45K1	-	1	-	-
Locking Impact Nail Driver-IN**	45K2	-	1	-	-

* Use Locking Impact Nail Driver - BS for installing base sheet and recovery board to the substrate: (for 1.4" and 1.8" fasteners only)
 ** Use Locking Impact Nail Driver - IN for securing ISO or EPS to the substrate: (for 2.8", 3.8" and 4.8" fasteners)



Quality You Can Trust Since 1886...
 from North America's Largest
 Roofing Manufacturer™

